



NSU-PRINZ 4



**The German
Compact
for Americans!**



When it was introduced four years ago, the Prinz had only NSU's worldwide reputation to back it up. Today, whenever and wherever knowledgeable people discuss light cars, the reliability, performance and durability of the NSU-Prinz are taken for granted - just as is the fact that NSU has proven it possible to build an economy-minded vehicle which can come up to the standards of performance normally expected from cars with engines at least twice the size.

Now we present the NSU-Prinz 4 — a model that sets new standards of elegance and comfort while retaining the robustness, fantastic roadholding, safety features and powerful engine of its predecessors.

At NSU we've always tried to turn out a product that comes as near to perfection as is humanly possible. And in keeping with this policy, we have not only changed the overall concept of the body but have also paid a lot of attention to detail.

Take a close look and you'll see. Go through the pages of this booklet — the five happy people on this page, the PRINZ family, will accompany you. At first glance, the pleasing lines of the Prinz 4 catch your eye. That second look will reveal the high standard of the interior appointments. Although this is an economical car at a more than competitive price, we haven't tried to economize on the materials used. No other car in this price group can offer as much to the buyer.

There are times when a big car can be a nuisance. Ever try to fit one into a small parking space on a hot summer day? A light car that handles easily is the answer to your problem — especially one that has ample room for four adults and their luggage.

The Prinz 4's overall length is a mere 11 feet, 3 inches, enabling it to slip through gaps in traffic and find those parking spaces wih larger cars are forced to pass up. Remember that old saying about good things coming in little packages?



NSU-PRINZ 4

Let's Look Inside



May we open the door for you?

Take a seat and make yourself comfortable — the NSU-Prinz 4 is indeed a comfortable car. The seats have been scientifically designed so they best support the body, and the angle of the back rests can be changed to suit anyone's individual taste. Want to go on a trip? You'll get out at the finish without even the slightest feeling of tiredness, another tribute to the built-in class of the NSU-Prinz 4.

Take a look around. From any seat, vision in the new Prinz 4 is excellent, and from behind the wheel it is the best offered in any light car, giving the driver that „extra“ which is so important in traffic. If you're interested in facts and figures, the total glass area in the NSU-Prinz 4 is no less than 19 square feet — more than in any comparable car..

Entry and exit are other departments in which the Prinz 4 really shines. Even back-seat passengers have an easy time getting in and out, thanks to the oversize doors.

And while you're sitting there, take a close look at the detail finish or the various fittings. Everything is in the renowned tradition of German workmanship — well done and of finest quality, making the Prinz as comprehensively equipped as a far more expensive car.

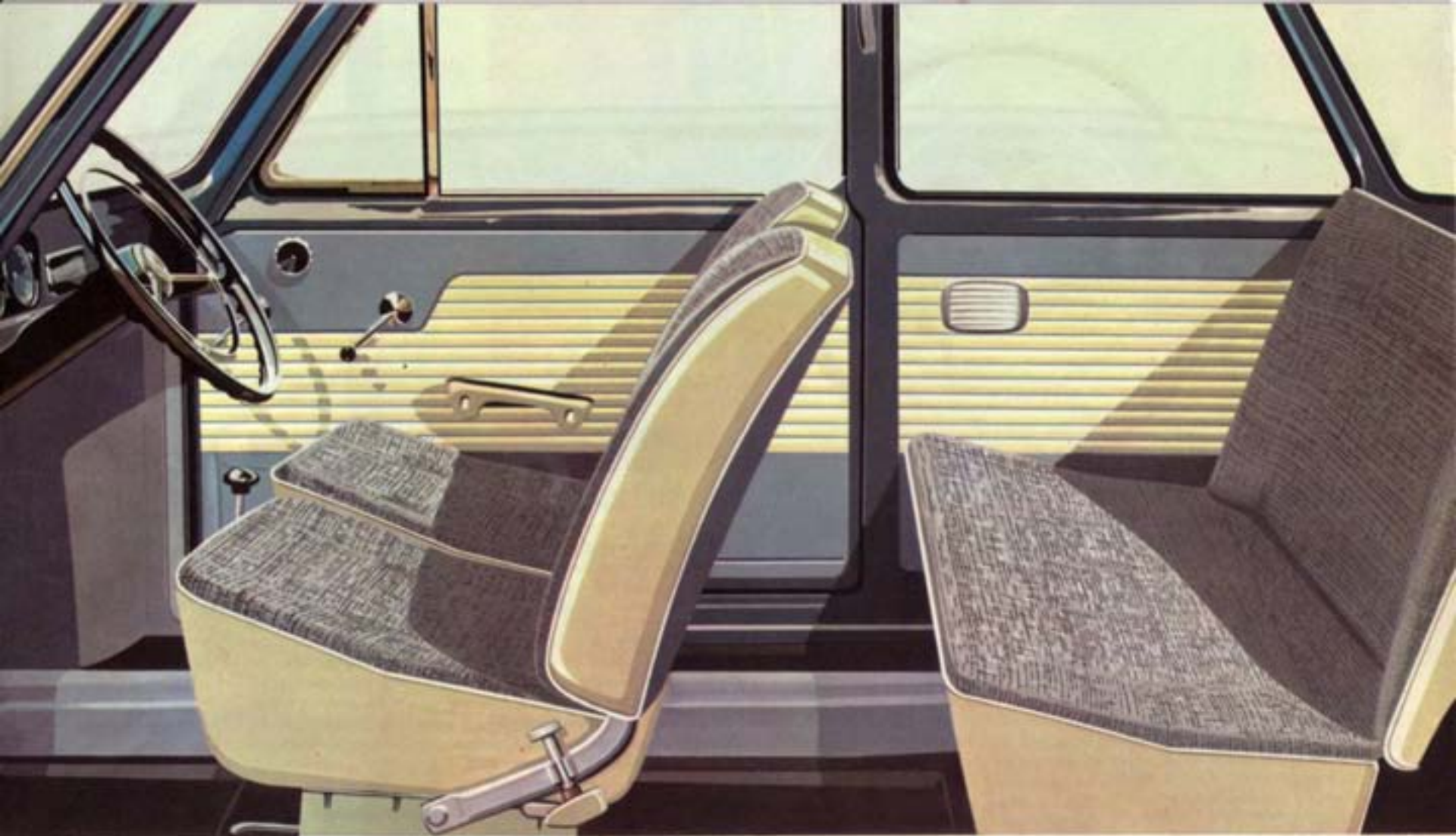

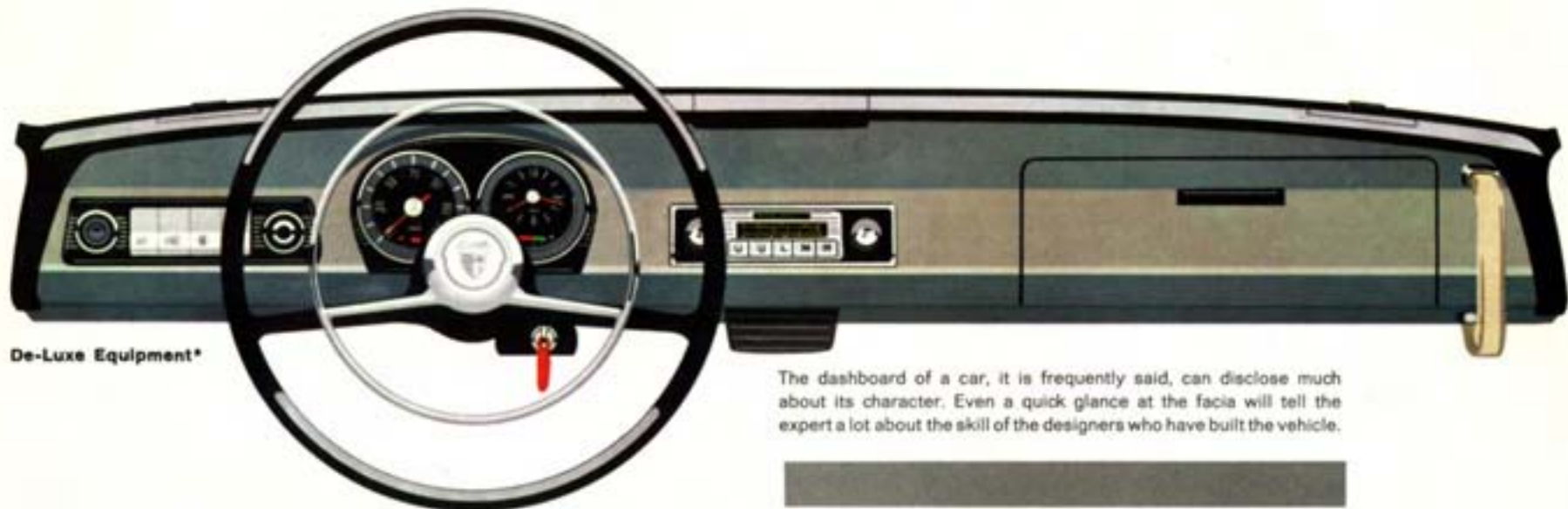

De-Luxe Equipment*

**Let's see
the dashboard**

The dashboard of a car, it is frequently said, can disclose much about its character. Even a quick glance at the fascia will tell the expert a lot about the skill of the designers who have built the vehicle.

Many a more expensive automobile doesn't have a dashboard that is as comprehensively equipped as the NSU-Prinz 4's. The instruments include a speedometer and a mileage recorder in one dial, and an electric clock sharing the other dial with a fuel gauge*. The speedometer dial also includes warning lights for the generator, oil pressure and full beam light.

Switches for the headlights and parking lights are conveniently located on the dash. There is also a socket for a signal lamp or cigaret lighter and there is another small warning light which goes on when the choke is being used. To the right of the steering wheel is an ashtray of generous proportions as well as provision for installing a radio, and there is a spacious glove compartment with lid fitted in front of the passenger's seat.

We feel the many fine things about our dashboard reflect the overall fine quality of the car. There are no other reflections, however. A neat top to the dash, finished in matt black, avoids any unwanted reflections in the windshield.

* — optional at extra cost.



The door windows can be rolled down flush with the doors, and even the standard version of the NSU-Prinz 4 has swivelling quarter lights at the front. These can be opened to any angle, and are controlled by a thief-proof wheel which makes the old lever-type lock outmoded.

In order to let Prinz 4 drivers take advantage of the great window area even in rain, NSU's engineers have positioned the wipers to that they clean an area practically equal to the height and width of the windshield. An efficient heater-defroster unit is, of course, part of the standard equipment.

Take a look at that trunk — here's real vacation luggage room! There are 8,8 cubic feet of space, and it will hold just about everything you'd care to take along with you. The cap for the 9,8-gallon fuel tank (350 miles on one filling!) is also safely tucked away under the hood with a special sealing area built around it so as to exclude fuel fumes from the car interior.



Take Your Seat, Take Measure



Here are our five friends again, comfortably seated in their NSU-Prinz 4 to show you how roomy it is (the artist has performed a little magic of his own, however, so that you can get a better look at it). Compact though it is, there's lots of room in the NSU-Prinz 4. The distance from the back of the front seat to the leading edge of the back one is no less than 26¹/₂ inches — more than many larger cars offer.

There's lots of legroom up front, too, as well as elbow room and headroom even for tall passengers*.

* — If you're 6-6 and wearing a top hat, you might have to take that chapeau off. We can't guarantee you'll fit with the topper.

Here's something for the enthusiast — the wonderful little engine built into a compact unit together with transmission and differential forming "one cast" with the solid rear axle. Even if you're not mechanically minded, you'll soon fall prey to its charms. Like the fighting heart of an athlete, this unit has been the "go" behind the almost uncountable number of race and rally victories NSU-Prinzes have piled up in the past few seasons. Packed with low-end acceleration, with real pep, the NSU-Prinz 4 power unit is also able to sustain high cruising speeds for hour after hour. Its sound is full and sportive, but not noisy (try from inside the car!).



As soon as the first NSU-Prinzes were introduced, they astounded everyone with their roadholding. Previously, such stability on all types of surfaces and at all speeds was the exclusive property of high-priced sports cars. And now the Prinz and its four-wheel independent suspension has become almost legendary for the way it corners. Two transverse wishbones are used to locate each wheel, and as before the Prinz employs anti-roll bar at the front. Long-travel coil springs and double-action shock absorbers are used fore and aft, and additional "Prinzair" pneumatic auxiliary pads are used at the rear. And with the further refinements the NSU-Prinz 4 has undergone, the absence of bottoming or dipping will make the ride anything but harsh.

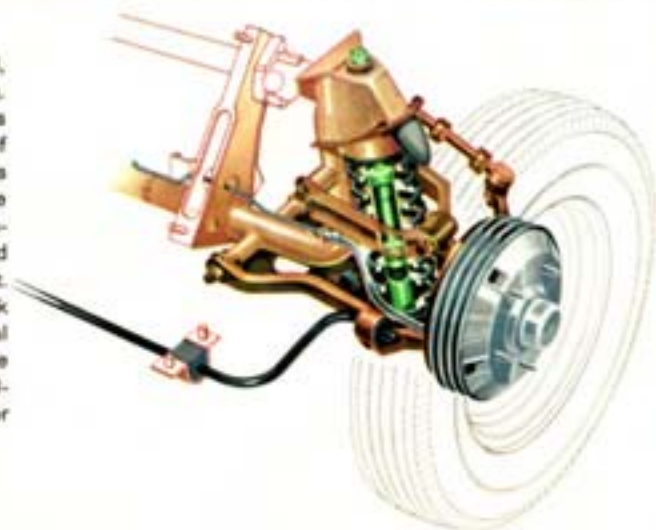

We have taken great care in developing a ventilating plant which meets even the most exacting requirements. Cool fresh air is taken in through a grille below the windshield, and the strength of the fresh-air stream can be adjusted to meet anyone's desires.

The same is true of the hot-air supply, which is ducted to the defroster and/or to the feet of the driver and front-seat passenger. Fresh air for the heating system is purposely drawn in at the back, thus avoiding the exhaust fumes of other vehicles. As shown in the lower illustration, the heating air never comes in contact with the engine or the exhaust system, reaching you in absolutely fresh condition.

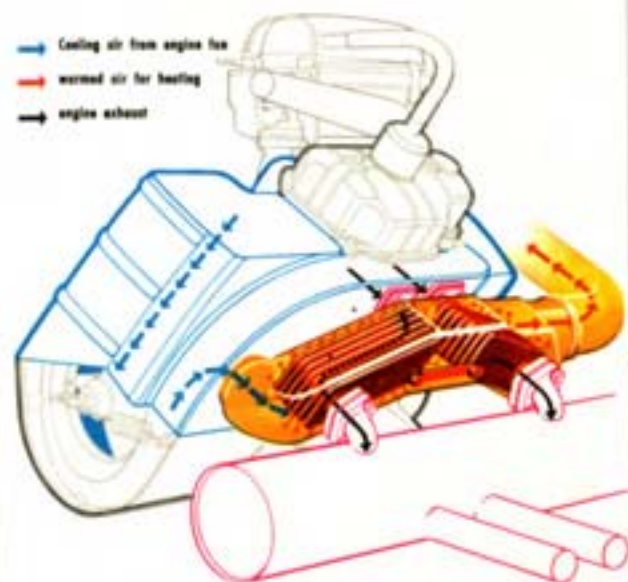

Like to do trips? NSU took this for granted when designing the Prinz 4, and didn't skimp on the seats or the size of the luggage area. In addition to the trunk space, there's also a handy spot for parcels behind the rear seat. And to top it off, the total carrying capacity of the Prinz 4 is 959 pounds — far more than any other car of comparable size and an exceptional amount even for a medium-sized vehicle.

So don't worry about loading it up when you set off on vacation. Empty or full, the Prinz 4 will carry you merrily over the Rockies or wherever else you might like to go. And let's not forget the financial side. The cost of a car is the sum of two parts — the purchase price and the running costs. The latter can in some instances add up to an amount exceeding the original price of the car after a few years. But not with the Prinz, which is as economical to drive and to maintain as a car can be. And the more you drive it, the lower your costs per mile go. So: long distance trips are, in fact, the opportunity to save money — lots of money! Just one more happy item to make Prinz 4 ownership more enjoyable!

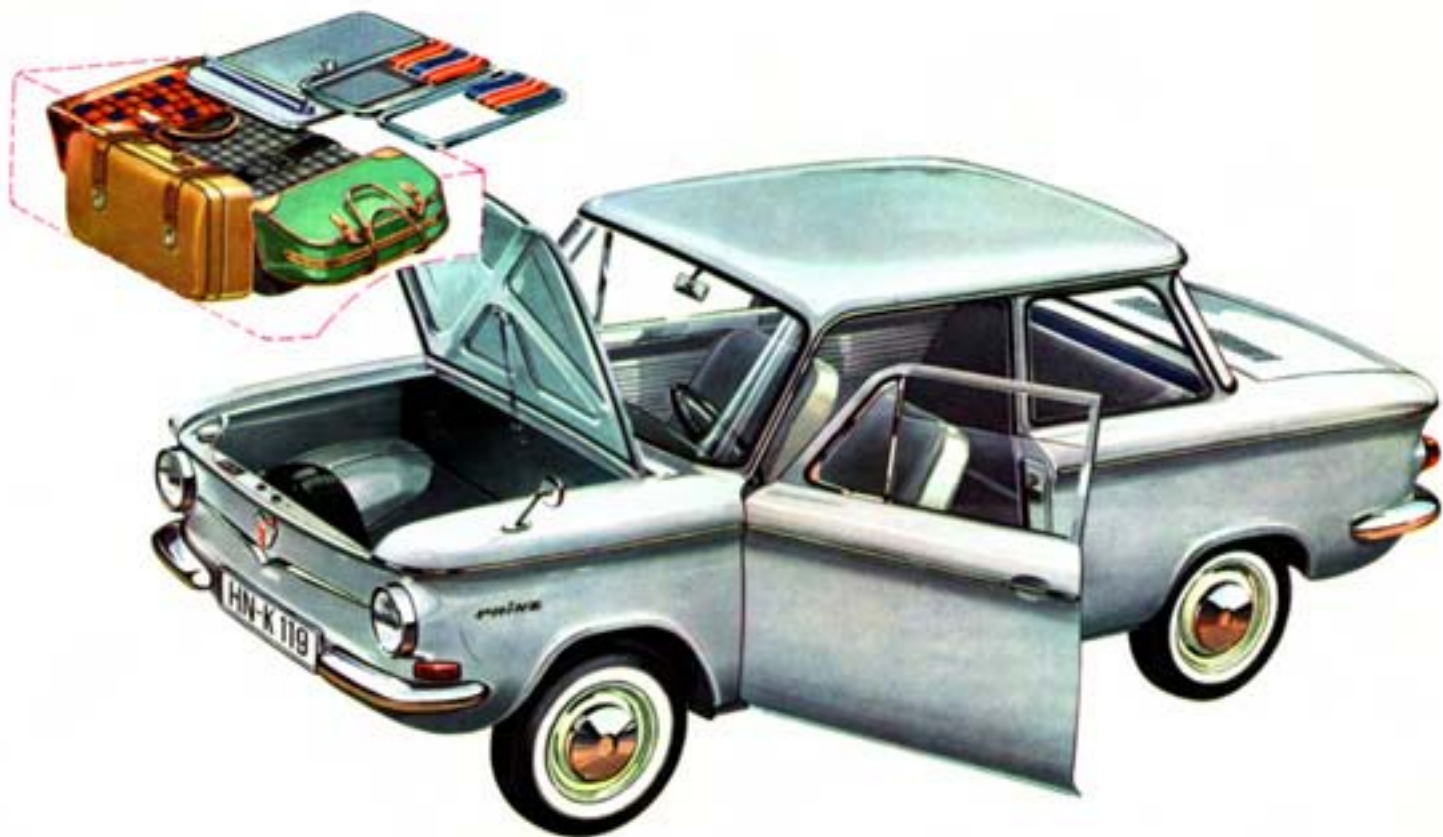

He is a Lucky Fellow who owns a PRINZ

Plain Facts

Specifications of the Prinz 4

Engine	Two-cylinder four-stroke, with valves actuated by overhead camshaft driven by eccentric rods offset at 90 degrees. Compression ratio - 7.5 to 1. Maximum torque - 33 foot-pounds at 3,250 rpm. Output - 36 horsepower (SAE) at 5,500 rpm.
Carburetor and Fuel System	Solex 34 PCI downdraft carburetor with accelerator pump and oilbath-type air cleaner. 9.8-gallon fuel tank located under luggage compartment. Fume-proof filler cap protected by lockable trunk lid. Mechanical fuel pump. Fuel gauge optional at extra cost (included in de-Luxe Equipment).
Electrical Equipment	12-volt starter-generator with 130-watt output. 32 ah battery, twin coils.
Cooling	By crankshaft-driven radial fan.
Clutch	Single dry plate.
Transmission	Four forward speeds and reverse, all forward speeds synchronized. Overall ratios: 1st- 19.89/1 2nd- 10.61/1 3rd- 6.77/1 4th- 4.80/1 reverse- 25.84/1 Drive to rear wheels via swing axles fitted with bonded-rubber universal joints. Transmission gears housed in crankcase extension.
Lubrication	Full-flow circulation serving engine and transmission simultaneously. Oil capacity two quarts. Interchangeable micronite filter.
Suspension	Front: Independent, incorporating transverse wishbones. Rear: Single, wide-base transverse wishbones. Long-travel helical springs and large double-action shock absorbers. Springs supplemented by rubber buffers at the front and

pneumatic "Prinzair" auxiliary pads at the rear. Anti-roll bar (stabilizer) connecting the lower front suspension wishbones.

Steering	Rack and pinion, needs no lubrication. Equal-length track rods. 3 turns lock to lock. Turning circle 29 feet.
Servicing	Only two grease nipples on front suspension require occasional attention.
Wheels and tires	Steel disc wheels 3.50 x 12. Tires - 4.80 x 12.
Body	All-steel unit body. Two-door sedan with enameled finish. Seating capacity, 4-5 persons. Luggage space in the nose of the vehicle, additional storage space behind rear seat. Dimensions of trunk space - 4'6" x 22 1/2" x 15 1/4" x 9 7/8 inches. Dimensions of rear storage area - 3'11 1/4" x 4 1/2" x 17 3/4 inches. Steel sliding roof optional at extra cost.
Instruments	Speedometer with markings indicating maximum speeds in each gear, distance recorder and warning lights for generator, oil pressure, headlights and turn indicators combined in one dial. Switches controlling parking, trafficators and headlights and control switches for windshield wipers located at left side. Ashtray fitted in center of dash; space provided for radio in center of dash. Glove compartment with lid located in front of passenger's seat. Levers on steering column operate dip switch and electric horn (left) and turn indicators (right). Padded sun visor fitted on driver's side.
Ventilation	Comprehensive heating and ventilating system with separate controls is standard equipment. Fresh air used for heating, passing through an exchanger without coming in direct contact with the engine, thus ex-

cluding fumes or unpleasant odors. Set of hot and cold controls for each of the front seats. Ventilation can be supplemented by windows which can be rolled down flush with the doors and swivel-mounted quarter lights.

De-Luxe Equipment

At an extra charge the NSU Prinz 4 can be fitted with de-Luxe equipment, which includes the following:

Second instrument cluster consisting of an electric clock and fuel gauge, windshield washer, row of tumbler switches controlling the parking lights, trafficators and headlights. Special parking lights provided. Also, courtesy light with built-in overriding switch, choke warning lamp, socket for hand lamp, second padded sun visor for front-seat passenger complete with vanity mirror in back, dashboard grab handle for passenger, two-color door trim including additional map pocket on passenger's side, horn ring on steering wheel and an electric horn with more penetrating note.

Further extras include a rope pull on each side combined with coat pegs and an ashtray for rear-seat passengers.

Principal Dimensions

Length: 11 ft. 3 3/8 ins., width: 4 ft. 10 1/4 ins., height: 4 ft. 5 1/2 ins., ground clearance: 7 ins., unladen weight, ready to travel: 1246 lbs., permitted carrying load: 959 lbs.

Acceleration

0-40 m.p.h. 9.2 seconds
0-50 m.p.h. 14.4 seconds

Maximum Speeds In Gears

1st - 18 m.p.h. 2nd - 34 m.p.h.
3rd - 53 m.p.h. 4th - 75 m.p.h.

Fuel

Consumption up to 41 miles per gallon.

Specifications subject to change without notice



Carefree? Yes, in more than one. They've not only arrived at their destination, but their NSU-Prinz 4 ran without even a hint of trouble for the entire trip. NSU's well-

developed network of dealers stands ready to serve you wherever you may be, and each of them is fully equipped to do what little servicing the Prinz 4 requires.



TRANSCONTINENTAL MOTORS, INC.
421 EAST 91st STREET
NEW YORK 28, N. Y.
212 JR 6-7013

NSU MOTORENWERKE AKTIENGESELLSCHAFT NECKARSULM

Printed in Germany DW 312 150 7135